

ULTRA Marine

- **Mandos de latón cromado (agua fría y caliente)**
 Chrome-plated brass mixer taps (cold and hot water)
Commandes en laiton chromé (eau froide et chaude)
- **Frontal ancho de acero en azul ultramarino**
 Wide steel front panel in ultramarine blue
Panneau frontal grand en acier en bleu ultramarine
- **Rociador de Ø150 mm**
 Ø150 mm showerhead
Pommeau de Ø150 mm
- **Colector solar 40L de aluminio**
 40L aluminum collector
Capteur solaire 40L en aluminium

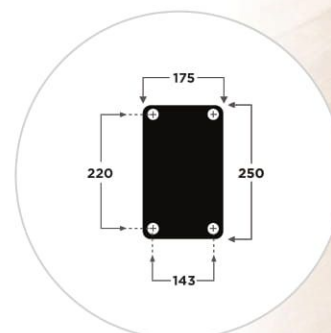

Dimensiones | Dimensions | Dimensions (mm)

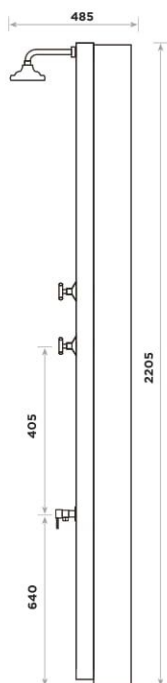

Características | Features | Caractéristiques

- **Frontal de ancho 114 mm con diseño registrado**
114 mm wide and registered front panel design
Panneau frontal, largeur 114 mm avec conception brevetée
- **Revestimiento especial y tratamiento anticorrosión**
Special coating and anticorrosive treatment
Revêtement spécial et traitement anticorrosion
- **Entrada de agua de ½" hembra en acero inoxidable**
Female ½" main water inlet in stainless steel
Entrée d'eau de ½" femelle en acier inoxydable
- **Conexión a entrada de agua mediante latiguillo flexible**
Connection through flexible water connector
Raccordement à l'entrée d'eau par tuyau flexible
- **Incluye conjunto anclaje: tornillos, tacos y arandelas**
Fixing set is included: screws, anchors and washers
Jeu d'ancrage inclus: vis, chevilles et rondelles
- **Tornillo de desagüe de acero inox**
Stainless steel drain plug
Vis de vidange en acier inoxydable

Referencia Reference Référence	Frontal Front Panneau frontal	Mandos Knobs Robinets	Rociador Showerhead Pommeau	Grifo accesorio / lavapiés Accessory tap / foot washer Robinet accessoire / rince-pieds
40ULT				-
40ULTGR				✓

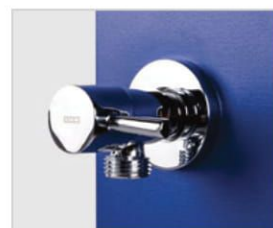
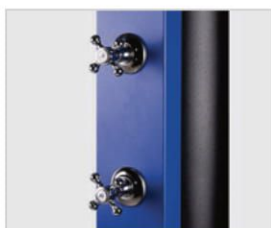
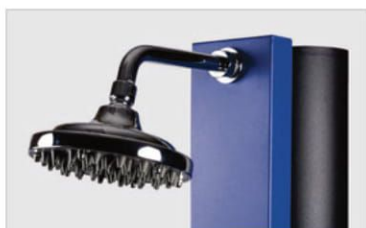

Accesorio / lavapiés
Accessory / foot washer
Accessoire / rince-pieds

Embalaje | Packaging | Emballage

- **Cartón Kraft ondulado de doble cara**
Kraft corrugated carton of double wall
Carton ondulé de double cannelure couverture Kraft
- **226 x 22 x 33**
Largo x ancho x alto (en cm)
Length x width x height (in cm)
Longueur x largeur x hauteur (en cm)
- **Peso | Weight | Poids: 15 kg**